

PMD VARIO

Telaio porta attrezzi a colonna mobile - Tool holder frame with mobile column
 Cadre porte-outils à colonne mobile - Multigeräteträger mobil

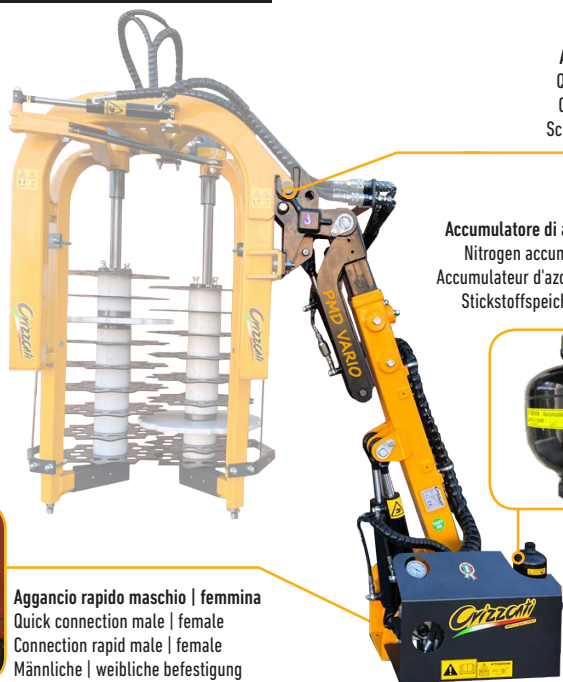

Aggancio rapido
 Quick connection
 Connection rapid
 Schnelle kopplung

Accumulatore di azoto per dischi
 Nitrogen accumulator for discs
 Accumulateur d'azote pour disques
 Stickstoffspeicher für Scheiben



Aggancio rapido maschio | femmina
 Quick connection male | female
 Connection rapid male | female
 Männliche | weibliche befestigung

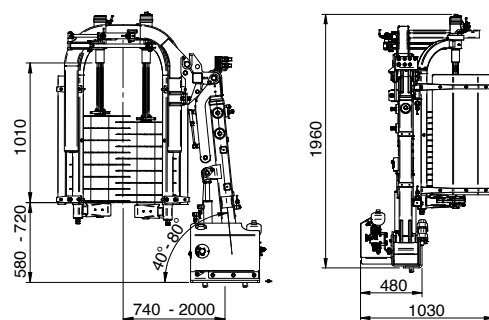
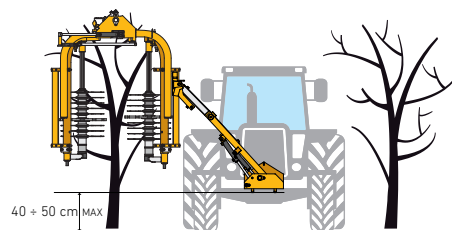

COD. Movimenti - Movements - Mouvements - Bewegungen

104605J

5+1



ON/OFF MOTOR

⚠ +3 MOVIMENTI LIBERI | +3 FREE MOVEMENTS | +3 MOUVEMENTS LIBRE | +3 FREI BEWEGUNGEN



Joystick



Distributor



310



Oil - Pressure

50 l/min 180 bar max



8+8 Dischi di serie
 8+8 Discs standard
 8+8 Disc compris
 8+8 Scheiben

DI SERIE

OPTIONAL

COD. 1A32200



N° 12 = L. 100 cm
 N° 10 = L. 80 cm
 N° 08 = L. 60 cm

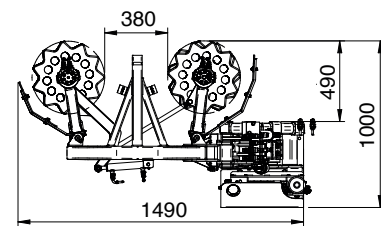
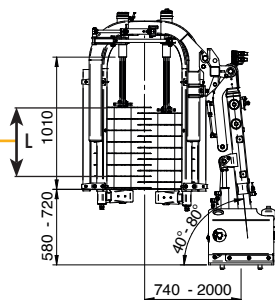

COD. Movimenti - Movements - Mouvements - Bewegungen

1U46450

5+1

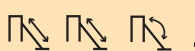

ON/OFF MOTOR



N°

8+8



Joystick



Distributor



190



Oil - Pressure

30 l/min 180 bar max

⚠ STAFFE PER TRATTORI E SERBATOI - TRACTOR BRACKETS AND OIL TANKS - SUPPORTS ET RÉSERVOIRS DE TRACTEUR - TRAKTORHALTERUNGEN UND TANKS

OPTIONAL Descrizione - Description - Description - Beschreibung

1A45030 Maggiorazione/Deazione per coppia dischi taglienti in HARDOX - Increase/deduction for pair of HARDOX discs
 Supplément/Dédution pour paire de disques à tronçonner en HARDOX - Zuschlag/abzug für ein Paar Schneidscheiben in HARDOX



1A45031 Coppia dischi salva-palo in PVC folli - Pair of pole-friendly PVC idle discs
 Disques de sécurité en PVC - Paar polfreundliche PVC-Leerlaufscheiben



1A45032 Coppia anteriore barre bilama L. 100 cm - Front pair of double-blade bars L. 100 cm
 Paire de barres double lame L. 100 cm avant - Vorderes Paar Doppelklingen L. 100 cm





Molla sicurezza top
Top spring security
Ressort de sécurité top
Top Sicherheitsfeder

Molla gas antiurto
Gas spring security
Sécurité avec vérin a gaz
Sicherheitsgasfeder

COD. 1A32205 **OPTIONAL**

Bilama / Guide PVC
Double blade / PVC support
Double section / PVC lamier
Doppelklingen- / PVC-Führungen



COD.	Movimenti - Movements - Mouvements - Bewegungen	Joystick	Distributor	Oil - Pressure
1U46320	4+1 + ON/OFF MOTOR			280
				30 l/min 180 bar max

STAFFE PER TRATTORI E SERBATOI - TRACTOR BRACKETS AND OIL TANKS - SUPPORTS ET RÉSERVOIRS DE TRACTEUR - TRAKTORHALTERUNGEN UND TANKS **Pag. 55**

OPTIONAL	Descrizione - Description - Description - Beschreibung	
1A32205	Convogliatore alzatralci idraulico - Hydraulic conveyer Convoyeur hydraulique - Hydraulischer Hebebandförderer	

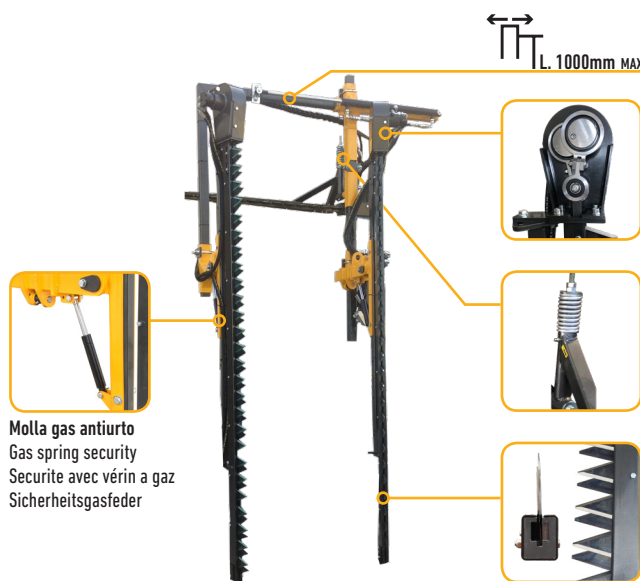

Molla sicurezza top
Top spring security
Ressort de sécurité top
Top Sicherheitsfeder

Molla gas antiurto
Gas spring security
Sécurité avec vérin a gaz
Sicherheitsgasfeder

COD. 1A32200

Bilama / Guide PVC
Double blade / PVC support
Double section / PVC lamier
Doppelklingen- / PVC-Führungen

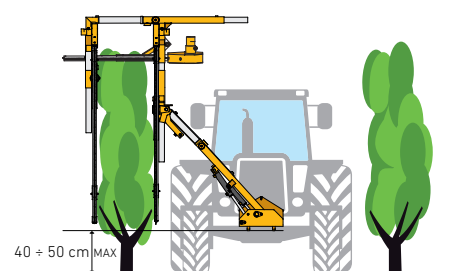

COD.	Movimenti - Movements - Mouvements - Bewegungen	Joystick	Distributor	Oil - Pressure
1U46325	4+1 + ON/OFF MOTOR			370
				30 l/min 180 bar max

STAFFE PER TRATTORI E SERBATOI - TRACTOR BRACKETS AND OIL TANKS - SUPPORTS ET RÉSERVOIRS DE TRACTEUR - TRAKTORHALTERUNGEN UND TANKS **Pag. 55**

OPTIONAL	Descrizione - Description - Description - Beschreibung	
1A32200	2 Convogliatori alzatralci idraulici - 2 Hydraulic conveyors 2 Convoyeur hydrauliques - 2 Hydraulische Hebebänder	

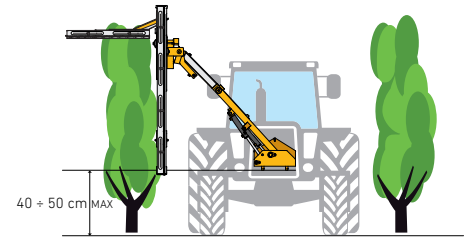
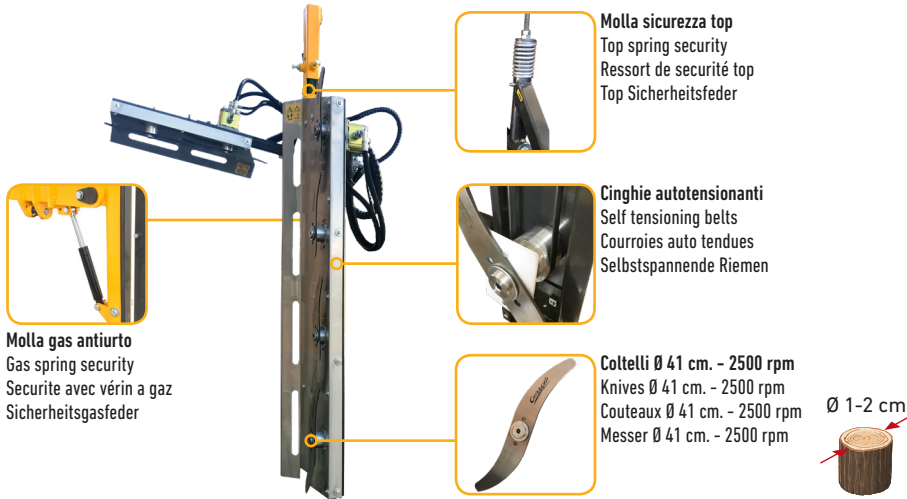

COD.	Movimenti - Movements - Mouvements - Bewegungen	Joystick	Distributore	Oil - Pressure
1U46330	A = 4 B = 2 4+1			160 30 lt/min 180 bar max
1U46331	A = 5 B = 2 4+1			280 30 lt/min 180 bar max

STAFFE PER TRATTORI E SERBATOI - TRACTOR BRACKETS AND OIL TANKS - SUPPORTS ET RÉSERVOIRS DE TRACTEUR - TRAKTORHALTERUNGEN UND TANKS **Pag. 55**

OPTIONAL Descrizione - Description - Description - Beschreibung

1A324000	Cottello inclinabile a regolazione meccanica - Tilting knife with mechanical adjustment Couteau incliné avec réglage mécanique - Kippmesser mit mechanischer Einstellung	
-----------------	---	--

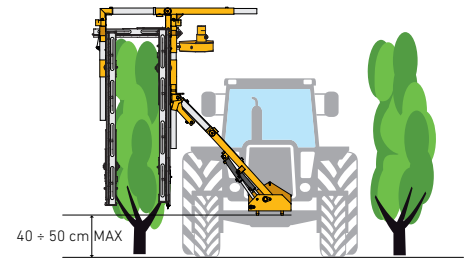
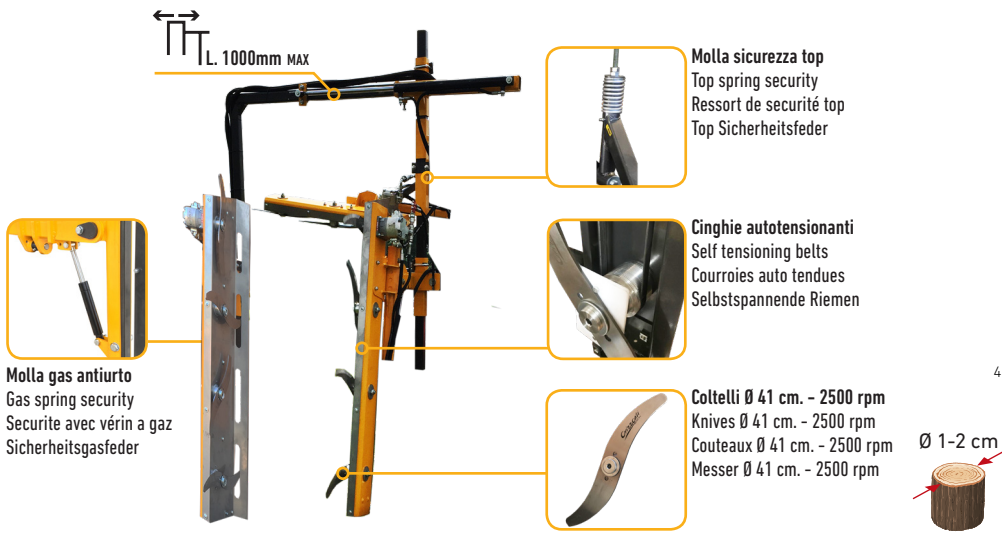

COD.	Movimenti - Movements - Mouvements - Bewegungen	Joystick	Distributore	Oil - Pressure
1U46335	A = 3 B = 2 4+1			180 30 lt/min 180 bar max
1U46336	A = 4 B = 2 4+1			215 30 lt/min 180 bar max
1U46337	A = 5 B = 2 4+1			225 30 lt/min 180 bar max

STAFFE PER TRATTORI E SERBATOI - TRACTOR BRACKETS AND OIL TANKS - SUPPORTS ET RÉSERVOIRS DE TRACTEUR - TRAKTORHALTERUNGEN UND TANKS **Pag. 55**

OPTIONAL Descrizione - Description - Description - Beschreibung

1A324002	Doppio cottello inclinabile DX/SX a regolazione meccanica - Double conveyor knife R/L with mechanical adjustment Double couteau inclinable D/G avec réglage mécanique - Doppelkippmesser R/L mit mechanischer Einstellung	
-----------------	--	--



Apertura idraulica tunnel
Hydraulic tunnel opening
Ouverture du tunnel hydraulique
Öffnung des Hydrauliktunnels

L. 70 cm
n° 13 cinghie
n° 13 straps
n° 13 sangles
n° 13 Gurte

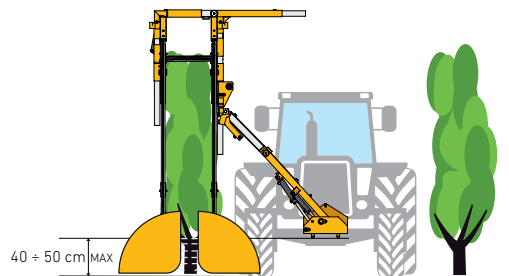

COD. Movimenti - Movements - Mouvements - Bewegungen

Joystick

Distributor

Oil - Pressure

1U46500

4+1 + ON/OFF MOTOR



160

30 l/min 180 bar max

STAFFE PER TRATTORI E SERBATOI - TRACTOR BRACKETS AND OIL TANKS - SUPPORTS ET RÉSERVOIRS DE TRACTEUR - TRAKTORHALTERUNGEN UND TANKS

Pag. 55



STAFFE PER TRATTORI E SERBATOI OLIO

TRACTOR BRACKETS AND OIL TANKS - SUPPORTS ET RÉSERVOIRS DE TRACTEUR - TRAKTORHALTERUNGEN UND TANKS

COD.	Descrizione - Description - Description - Beschreibung		Kg
1A32051	Staffa fissa maschio grezza per CIMATRICI Raw male fixed bracket for TRIMMERS Support fixe mâle pour ROGNEUSES Rohe männliche feste Halterung für REBSCHNEIDER		25
1A44051	Staffa fissa maschio grezza per PRO CUT Raw male fixed bracket for PRO CUT Support fixe mâle pour PRO CUT Rohe männliche feste Halterung für PRO CUT		70
1A32052	Staffa fissa maschio grezza per FRUIT Raw male fixed bracket for FRUIT Support fixe mâle pour FRUIT Rohe männliche feste Halterung für FRUIT		40
1A32050	Staffa fissa al trattore per CIMATRICI (fornire modello e tipo di trattore - vedi pag. 176-178) Bracket fixed to the tractor for TRIMMERS (type and version of tractor - see page 176-178) Support fixé au tracteur pour ROGNEUSES (indiquez le modèle et le type de tracteur - voir page 176-178) Am Traktor befestigte Halterung für REBSCHNEIDER (Modell und Typ des Traktors angeben - siehe seite 176-178)		45
1A44052	Staffa fissa al trattore per PRO CUT (fornire modello e tipo di trattore - vedi pag. 176-178) Bracket fixed to the tractor for PRO CUT (type and version of tractor - see page 176-178) Support fixé au tracteur pour PRO CUT (indiquez le modèle et le type de tracteur - voir page 176-178) Am Traktor befestigte Halterung für PRO CUT (Modell und Typ des Traktors angeben - siehe seite 176-178)		85
1A32053	Staffa fissa al trattore per FRUIT (fornire modello e tipo di trattore - vedi pag. 176-178) Bracket fixed to the tractor for FRUIT (type and version of tractor - see page 176-178) Support fixé au tracteur pour FRUIT (indiquez le modèle et le type de tracteur - voir page 176-178) Am Traktor befestigte Halterung für FRUIT (Modell und Typ des Traktors angeben - siehe seite 176-178)		55
1A32070	Attacco a tre punti con aggancio rapido per CIMATRICI Three-point hitch with quick coupling for TRIMMERS Attelage trois points avec attelage rapide pour ROGNEUSES Dreipunktaufhängung mit Schnellkupplung für REBSCHNEIDER		50
1A32090	Attacco a tre punti con aggancio rapido per PRO CUT Three-point hitch with quick coupling for PRO CUT Attelage trois points avec attelage rapide pour PRO CUT Dreipunktaufhängung mit Schnellkupplung für PRO CUT		110
1A32071	Attacco a tre punti con aggancio rapido per FRUIT Three-point hitch with quick coupling for FRUIT Attelage trois points avec attelage rapide pour FRUIT Dreipunktaufhängung mit Schnellkupplung für FRUIT		60
1A48000	Serbatoio idraulico 60 lt olio con pompa GR.2, radiatore per CIMATRICI BILAMA / COLTELLI / PRO CUT Hydraulic tank 60 lt oil with pump GR.2, radiator for TRIMMERS DOUBLE BLADE / KNIVES / PRO CUT Réservoir hydraulique huile 60 lt avec pompe GR.2, radiateur pour ROGNEUSES / DOUBLE LAME / COUTEAUX / PRO CUT Hydrauliktank 60 lt Öl mit Pumpe GR.2, Kühler für REBSCHNEIDER / DOPPELKLINGE / MESSERN / PRO CUT		180
1A48040	Serbatoio idraulico 60 lt olio con pompa GR.3, radiatore per INTERCEPPI / PFD / FRUIT / PRO CUT 1000 Hydraulic tank 60 lt oil with pump GR.2, radiator for INTER ROW / PFD / FRUIT / PRO CUT 1000 Réservoir hydraulique huile 60 lt avec pompe GR.2, radiateur pour INTERCEPS / PFD / FRUIT / PRO CUT 1000 Hydrauliktank 60 lt Öl mit Pumpe GR.2, Kühler für STOCKKRÄUMER / PFD / FRUIT / PRO CUT 1000		190
1A0090004	Albero cardano categoria 6 - L = 90 cm P.T.O. drive shaft category 6 - L = 90 cm Arbre à cardan catégorie 6 - L = 90 cm Kardanwelle der Kategorie 6 - L = 90 cm		
1A32001	4 ruote cavalletto per CIMATRICI 4 wheels stand for TRIMMERS 4 roues support pour ROGNEUSES 4 Räder stehen für REBSCHNEIDER		10
1A32003	4 ruote cavalletto per PFD/FRUIT/PRO CUT 4 wheels stand for PFD/FRUIT/PRO CUT 4 roues support pour PFD/FRUIT/PRO CUT 4 Räder stehen für PFD/FRUIT/PRO CUT		10